

# 9600 BAUD

## PACKET RADIO MODEM PCB

by James Miller G3RUH

This design is a high performance full duplex baseband modem designed for terrestrial packet and satellite packet use with typical voiceband NBFM radios, assuming only minor modifications.

The conventional packet VHF/UHF radio data rate is 1200 baud because all TNCs provide an internal modem for this speed, and the two-tone AFSK audio spectrum suits unmodified voiceband radios comfortably. However all TNCs can generate much higher data rates, and most FM radios have an unrealised audio bandwidth of some 7-8 kHz or more. So in many cases 9600 baud radio transmission is entirely practical with them.

A key feature of this modem is its digital generation of the transmit audio waveform. Precise shaping compensates exactly for the amplitude and phase response of the receiver. This results in a matched filter system, which means that the received audio offered to the data detector has the optimum characteristic eye for minimum errors. It also allows very tight control of the transmit audio bandwidth. For additional information see *ARRL 7th Computer Networking Conference Papers 1988*, pages 135 - 140. Internet file: <ftp://ftp.amsat.org/amsat/articles/g3ruh/a109.zip>

**MODULATION:** FM. Audio applied direct to TX varactor.  $\pm 3$  kHz deviation gives RF spectrum 20 kHz wide (-60dB). Fits standard FM channel easily.

**TX MODULATOR:** 8 bit long digital F.I.R. transversal filter in Eprom for transmit waveform generation (12 bit optional) designed using DSP techniques. Gives absolutely *brick-wall* audio spectrum. Typically -6 dB at 4800 Hz, -50 dB at 7500 Hz. Allows compensation for receiver (the channel) to achieve perfect RX *eye*. Up to 16 TX waveforms (32 optional), jumper selectable. Output adjustable 0-8V pk-pk.

**SCRAMBLER (Randomiser):** 17 bit maximal length LFSR scrambler. Compatible with satellites UO-22, Kitsat KO-23 etc as well as with manufacturers PacComm NB-96, Sprint-2, Kantronics DE-9600, TASC0 TMB-965, MFJ-9600, Symek TNC2H, BayCom PCM-4, K9NG, TAPR and many others.

**RX DEMODULATOR:** Audio from receiver discriminator, 5mV-10V pk-pk. Gentle 3rd order Butterworth noise filter, 6 kHz. Data Detect circuit for use on simplex (CSMA) links. Independent un-scrambler.

**CLOCK RECOVERY:** Unique digital phase-lock loop (DPLL) clock recovery circuit with 1/256th bit resolution, yet using only 16x clock. Average lock-in time 50 bits, depending on SNR.

**CONNECTS to AX.25 TNC Modem disconnect** jack. Suitable for TNC-2 and any other provided the internal modem can be bypassed. Standard TNC digital connections needed: TXData, TXClock (16x bit rate), RXData, Data Detect (DCD, high or low), GND. RXClock output available. TTL levels. RADIO connections: TXAudio, RXAudio, GND. All connections via 0.1" pitch pads for SIL connectors or direct soldering. Unwired DIN 41612 96-way connector (use optional).

**POWER CONSUMPTION:** 10 to 15V DC at 40mA (CMOS Roms), 170mA (NMOS Roms). Total 19 ICs (13 CMOS, 2 DACs, 2 Eproms). 5 Volt regulator and heatsink.

**OTHER FEATURES:** The only set-up is TXAudio level. Will run speeds up to 64,000 baud if some filter components changed. Channel calibration facility. Audio loopback. Jumper selectable Data or BERT (bit error rate test) mode.

**PCB:** 160x100mm single Eurocard format. Top professional quality, double sided, max copper ground plane, plated through, solder resist, yellow silk-screen/legend. Four 3.3 mm mounting holes. Comprehensive documentation in 16 page booklet. No hard-to-get parts.

**ORDERING:** PCB £18 post paid UK/Europe, £19 air-mail elsewhere. CMOS TX and RX Eproms (programmed), when ordered at the same time as the PCB, £6/pair. DACs £5/pair. Built and tested PCB £65. Any eproms ordered separately £5 each chip. You are free to copy the eproms if you wish.

Sterling Cheques, Eurocheques (max £150), Travellers Cheques, Cash, or bank draft drawn on a London bank. Also electronic funds transfer, please add £6 bank charges. No credit cards. You can "buy" English pound notes at many banks. I will also accept US dollars in cash only (green notes/travellers cheques) at a rate of \$2 per pound. Prices include postage and packing.

## SECTION 1 - APPLICATION

### 1.1 APPLICATION - TNCs

This modem is obviously only suitable for your TNC if its internal modem can be bypassed, and if it provides for the TTL digital signals:

- |                          |            |          |
|--------------------------|------------|----------|
| • TXData                 | e.g. TNC-2 | J4-19    |
| • TXClock (16x bit rate) |            | J4-11    |
| • RXData                 |            | J4-17    |
| • Data Detect ("DCD")    |            | J4- 1    |
| • GND                    |            | J4-15    |
| • RXClock (optional)     |            | not used |

TAPR TNC-2 based designs do this, typified by the TNC-2, PK-80, MFJ1270, TNC-200, Tiny-2, BSX-2, TNC2s, TNC2-DL etc. The PK-87, PK-88, and TNC-220 are also suitable. PK232 fails in full duplex.

### 1.2 APPLICATION - RADIOS

The ideal is to have a flat DC-8 kHz radio link. The "better" the TX and RX specification, the better the received data at the detector, and hence less susceptibility to errors.

Some apparently horrid receiver responses still offer useable service, but with a typically 2.5 dB reduction in performance. A good radio achieves about 1.5 dB implementation loss (compared with a perfect link).

Remember that you are pushing most radios to their limit since they were designed for speech where even 100% distortion is still intelligible. A little more finesse is required for data transmission.

#### 1.2.1 RECEIVERS

- NBFM design
- Output from discriminator (essential)
- Response virtually to DC (essential)
- Response no worse than -4 dB at 4.8 kHz
- No worse than -10 dB at 7.2 kHz
- As smooth/flat a phase delay as possible
- As smooth an amplitude response as possible
- Little change in response with 2 kHz de-tuning off-channel
- Symmetric, linear FM discriminator characteristic

On the whole, most receivers will perform as required. Those with the least complicated IF filtering appear best, especially with type "D" 20 kHz channel filters (e.g. CFM455D), though the "E" (16 kHz) is OK too.

8 kHz filters for 12.5 kHz channel spacing are too narrow for 9600 baud, but can be used at 4800 baud with  $\pm 1.5$  kHz deviation. However in this case all filter capacitors must be doubled in value (C26-32), and R6 changed to 220k. The modem can also be used up to 64 kbaud if the IF bandwidth is of order 100 kHz.

#### 1.2.2 TRANSMITTERS

- MUST generate true FM, as linearly as possible
- Deviation response DC to 7.2 kHz flat (essential)
- Deviation at 4800 Hz to be  $\pm 3$  kHz peak (maximum)

Transmitters based on crystal oscillator/multipliers are likely to be the most appropriate typically ex-PMR base stations.

Transceivers (synthesised or not) that have quite separate oscillator sub-systems for generating FM and possibly SSB/CW, which is then mixed with a synthesised source to produce the final carrier are OK.

Simpler synthesised FM transmitters, where the varactor modulated oscillator is within the synthesis PLL are generally not useable, as the PLL tracks the impressed modulation at low frequencies (typ. < 150 Hz) and you get no LF response. There are ways around this by additionally modulating the PLL reference xtal at LF. This is called 2-point modulation.

Remember you need true FM, which means a varactor diode pulling the oscillator frequency, NOT phase modulating a tuned circuit.

## SECTION 2 - HARDWARE DESCRIPTION

The modem consists of two independent parts - transmitter and receiver - sharing only clock and power supplies. See circuit diagram, centre pages.

### 2.1 MODEM TRANSMIT

Outgoing transmit data is clocked into D-type bistable U17a on a high going edge of TXClock (P2 pin 3), and then enters a randomiser/scrambler comprising 17 stage shift register U14/U18/U17b and EXOR gates U13. So, in transit through U14 are 8 bits of the TXData sequence, scrambled.

These 8 bits are used to look up a waveform profile for one period of that bit sequence, from TX Eprom U15. Four samples/bit make up the waveform, and jumpers JMP1-4 allow pre-selection of 16 different characteristics. JMP8 selects an alternative 16 from an Eprom type 27256.

The Eprom output is passed to digital-to-analogue converter (DAC) U19, which generates a discrete staircase-like waveform. This is then smoothed by a four pole anti-alias filter and the transmit audio (TXAudio) is output at P3 pin 1 to modulate the FM radio transmitter.

If jumper JMP5 is ON b-c or OFF, the scrambler generates a repeated sequence of 131071 random bits (duration 13.7 sec) which can be used for bit error rate testing BERT (see section 11.1 Reference - Jumpers).

Jumpers JMP1-4 set to ON b-c may, in conjunction with a special Eprom, be used to generate higher precision waveforms, say those optimised for dedicated radio links (see section 5 - Calibrating a Radio Link).

Jumper JMP6 is for audio loopback testing. Jumper JMP7 allows the DAC to be disconnected, and a test signal to be injected at TP2. R4 is the same as the DAC output impedance, 10k Ohms.

The scrambling polynomial is  $1 + X^{12} + X^{17}$ , one of the eight maximal length generators possible using a one-tap 17 bit shift register.

### 2.2 MODEM RECEIVE

Received audio (RXAudio) is passed through a 3 pole low pass filter, and limited by U10 pin 1. It is then sampled by the receive clock from U11 pin 10, and latched in D-type bistable U5a.

Detected data next enters a 17 bit shift register U12/U7/U5b, is unscrambled by EXOR gates U6, and sent to the TNC as received data (RXData) on P2 pin 4.

Eight bit shift register U4 is a 1/2 bit delay, and with EXOR U6 pin 3 forms a zero-crossing detector (ZCD) that generates one cycle of 9600 Hz for each zero crossing of the incoming audio.

This ragged *proto-clock* is used by a digital phase locked loop (DPLL) to regenerate a continuous received clock (RXClock). U1/U3 is an up/down counter phase detector, counting UP if the proto-clock input at pins 15 is late, DOWN if early with respect to the local clock at pins 10.

This counter looks up one of 256 sinewave profiles (16 steps per cycle) stored in Eprom U2, which is converted to analogue by a DAC U9, smoothed by C18, and limited to a square wave at U10 pin 2. In this way the recovered clock is pulled into phase with the incoming data at U10 pin 1.

Recovered clock and proto-clock are "multiplied" in EXOR U6 pin 6 and if in phase, a net DC rise accumulates on C21. Comparator U10 pin 13 senses this, pulling the data carrier detect line (DCD) P2 pin 5 low. An alternative DCD high is available at U10 pin 14. (Sect 11.3.2).

There are test points for receiver monitoring (see section 11.2, Reference - Test Points).

## SECTION 3 - INSTALLATION

The modem interconnects at connectors P1 (power), P2 (digital) and P3 (radio). Full specifications for the signals are given in section 11.3 - Reference - Connectors.

### 3.1 POWER

A 10 to 15 Volt stabilised supply connects to modem P1 pin 2, ground pins 1 & 3. The current consumption will be about 40 mA if CMOS Eproms are used, and up to 170 mA with NMOS devices. Either performs equally well. If a TNC-2 is used, switched power is conveniently obtained from across its 1000 µF reservoir capacitor C12.

### 3.2 DIGITAL CONNECTIONS

These vary from TNC to TNC, but nevertheless there are common requirements. TNC outputs TXData and TXClock can be run out without cutting TNC tracks. However TNC inputs RXData and DCD replace the internal signals, so TNC internal circuits must be disconnected by track cuts or jumper removal. It is rarely necessary to use the modem's RXClock, but you may if you wish. Do not confuse the modem's DCD with the RS232 signal of the same name.

#### 3.2.1 Connections to TNC-2

This modem replaces your TNC's standard internal modem. The connections to do this are provided on the TNC board on the *Modem Disconnect Jack*, labelled J4. There will be no actual connector, though the pin-out was designed by TAPR to accept a 20 pin IDC plug if required. As the modem connects to TNC-2 J4's odd pins only, a 10 pin SIL connector may conveniently be used. You **MUST** cut the trace between J4-17 and 18. Modem P2-6 is not used.

	TNC-2	J4		Modem	Digital	
	Evens	Odds		P2	Signal	
	2	-----	1	5	DCD	Showing connections to a TNC-2 Modem Disconnect Header J4.
	4	-----	3			
	6	-----	5			
	8		7			
	10	-----	9			
	12	-----	11	3	TXClock	All links shown must be present. On new unpopulated boards they may be missing, and must be installed.
	14	-----	13			
	16		15	2	GND	
Cut track-->	18		17	4	RXData	
	20	-----	19	1	TXData	

#### 3.2.2 Connections to AEA PK-87

(AEA circuit 012-060 Rev A & E). This TNC provides signals at the "Ext Modem" socket J4:

Signal	PK-87	J4	MODEM	P2	
TXData	1		1		NOTE: Old & New Models differ. OLD have 2.5 MHz xtal, and a TXClock = 9600 Hz. NEW have 4.9 MHz xtal, and a TXClock = 153.6 kHz. TXData, RXData and DCD: cut jumper links at JP3,JP4 and JP5, and re-bridge to other side.
GND	2		2		
TXClock	3	†	3		
RXData	4		4		
DCD	5		5		

† NEW models only. On OLD models obtain 153.6 kHz from PK-87 U20 pin 11.

#### 3.2.3 Connections to AEA PK-88

(AEA circuit 012-060-88 Rev G). This TNC provides signals within the RS232 connector J1.

Signal	PK-88	J1	MODEM	P2	
TXData	16		1		† TXClock: Cut internal track to J1 and obtain 153.6 kHz from PK-88 U20 pin 11.
GND	17		2		
TXClock	13	†	3		RXData, TXData, DCD: Cut the 3 jumper tracks at JP4 and re-bridge to other side.
RXData	15		4		
DCD	14		5		

### 3.2.4 Connections to Pac-Comm TNC-220

WARNING! Pac-Comm's circuit diagrams vary, have errors and differ from the actual PCBs! Some of the signals are at 20 pin IDC facility J5.

Signal	TNC-220	J5	MODEM	P2	
TXData	19		1		† TXCLOCK: Obtain 153.6 kHz from the TNC's 74HC4020 divider chip pin 5, and connect to modem P2-3.
GND	15		2		
TXClock	†		3		Cut track between TNC J5 pins 3 & 4: See note below. Cut track between TNC J5 pins 1 & 2
RXData	3		4		
DCD	1		5		

RXData: Some models have a second path in parallel with this track! Locate and cut it too.

### 3.2.5 Connections to Pac-Comm Tiny-2

Signal	Tiny-2	J5	MODEM	P2	
TXData	19		1		† TXCLOCK: Obtain 153.6 kHz from the Tiny-2 shorting link JPR, and connect to modem at P2-3. New models <i>may</i> have correct signal at J5.
GND	15		2		
TXClock	(11)†		3		Cut track between TNC J5 pins 17 & 18 Cut track between TNC J5 pins 1 & 2 - see below.
RXData	17		4		
DCD	1		5		

The DCD LED will not function unless you re-wire it correctly to Tiny-2 J5 pin 1 (is pin 2). This may have been corrected in newer models.

## 3.3 CONNECTING TO RADIO

There are three connections to a radio; TXAudio, RXAudio and PTT.

### 3.3.1 TRANSMITTER

PTT is the normal signal obtained from a TNC on its conventional 5 pin DIN audio connector pin 3, ground pin 2. This signal is not needed by the 9600 baud modem.

TXAudio should be taken from modem P3 pin 1, ground pin 2 directly to the transmitter varactor diode as noted in section 1.2.2, Application - Transmitters. You CANNOT inject the signal into the Microphone socket. The signal lead MUST be screened.

Modem adjustment VR1 allows you to set the drive level, which should result in a peak FM deviation of no more than  $\pm 3$  kHz for normal 20-25 kHz wide channels.

A signal of up to 8 Volts pk-pk is available, but if less than 1 Volt is needed, it is recommended that a high level is used, and a simple resistive attenuator be fitted at the transmitter.

IMPORTANT: The output has been designed for a load of 500 Ohms. If you use a higher impedance load, reduce C34 in proportion. This will ensure the correct low frequency response down to 3 Hz, and hence control any key-up "chirp". For example, if the transmitter load is 10k Ohms, use a coupling capacitor of  $10\mu \times 500/10000 = 0.5 \mu\text{F}$ . This may be placed in series with C34, and can be conveniently located in the transmitter.

There will always be a TXAudio signal, even when the PTT is not active. If possible the modulated oscillator should remain powered during receive to avoid keying chirp. Chirp will cause the distant receiver to take longer to lock-in.

### 3.3.2 RECEIVER

RXAudio MUST be brought direct from the receiver FM discriminator, and connects to modem P3 pin 4, ground pin 5. The RX audio lead MUST be screened. A decoupling RC network of time constant not exceeding 10 $\mu\text{s}$  is permissible at the discriminator to remove extraneous IF noise, but is not essential. The signal must be unswitched (it almost certainly is anyway).

You CANNOT use the receiver loudspeaker output for this system, though you can monitor reception by ear on it. The signal sounds like a burst of noise.

The modem audio input impedance is approximately 50k Ohms, AC coupled. In a full-duplex system (i.e. continuous transmit and receive) ONLY, modem C25 may be increased to 1  $\mu\text{F}$ . Do NOT alter it for normal simplex service or the modem receive transient performance will be affected, resulting in slow lock-in.

## SECTION 4 - OPERATION

### 4.1 JUMPER SETTINGS

Eight jumpers are provided on the modem PCB to configure the system, and allow user experimentation. Positions for NORMAL operation are:

Jumper	Function	Normal Position	Result
JMP1-4	TX Waveform Select	As required	See TXEPROM Sheet
JMP5	Data/BERT Mode select	ON a-b	Data Mode
JMP6	Audio loopback	OFF	No loopback
JMP7	TX DAC connect	ON	Connected
JMP8	TX Waveform II	OFF	See TXEPROM sheet

The data sheet supplied with the transmit waveform Eprom will indicate its contents, and the settings for JMP1-4 and JMP8. Note that the selection compensates for the DISTANT receiver - not your local receiver.

The receiver your link uses may not feature in the Eprom contents list. Nevertheless, most NBFM radios responses are quite similar and one selection, often number 10 in Eprom "TXBeta1", should be found acceptable; use selection 10 with an access node, digipeater or BBS.

You should examine the received "eye" diagram (see section 10 - Eye Diagrams) while the sender tries different JMP1-4 combinations. At least one of them will be "best". Repeat for the other TX/RX combination. Obviously this is more easily tried out with all radios in one room.

You can also calibrate a radio channel, and have a custom Eprom blown for it (see Section 5 - Calibrating a Radio Link).

It is vital that the radios are tuned to the correct frequency. If they are mis-tuned by more than 2-3 kHz, distortion will be apparent on the received signal, which will rapidly degrade performance. Some receivers have AFC, which will be helpful if it pulls in within 50 ms and also does not try to track the data and so impair the link's LF performance.

### 4.2 OPTIMUM TNC SETTINGS

These are a matter for individual experimentation. TXDELAY = 0 can be used on a full duplex link. On simplex try TXDELAY = 20 or 30ms for transmitters with solid-state antenna changeover, and TXDELAY = 40 ms or more if there are relays. If you find a TXDELAY of 100 ms or more is needed you probably have a key-up "chirp" problem. Check system coupling time constants. This is VERY important (see section 3.3.1).

Other significant settings are DWAIT=0 and FRACK = 1. Don't forget FULLDUP=ON for a full duplex link and also audio loopback testing.

More efficient use of the channel can be made if packets are long and concatenated, so set MAXFRAME = 7, and PACLEN = 255. Sometimes it's better to use a SENDPAC character other than \$OD <return>. In some instances data is sent faster from terminal to TNC if ECHO = OFF. Better still by far, use TRANSPARENT mode.

Obviously the TNC radio speed should be set for 9600 baud. On a TNC-2, this is SW2 : positions 6,7,8 = OFF,OFF,ON. Other TNCs require a command or an internal jumper change.

## SECTION 5 - CALIBRATING A RADIO LINK

There may be occasions where the transmit waveform in the standard TX Eprom is not suitable, and you would like a characteristic customised to your specific link. You can do this by making measurements on the receiver, and submitting them to the address below.

What you must do is measure the amplitude and phase response of the receiver you will use from 0-9600 Hz, in steps of 300 Hz, i.e. 33 points.

### Calibrating a Receiver Only

You will need a sinewave audio oscillator which covers up to 9600 Hz, an RF signal generator and accurately calibrated dual beam oscilloscope. Use the audio to frequency modulate (FM) the RF with a

deviation  $\pm 1$  kHz. Display the audio source on 'scope channel 1 which should also be used as Trigger.

Inject RF into the radio. On 'scope channel 2 display the RX discriminator output. Obtain audio output DIRECT from the discriminator with none of the de-emphasis components affecting things. You may have to make some mods to do this. A tiny bit of RC filtering is permissible to remove the 910 kHz IF noise. Try 100k/100p, i.e. a 10  $\mu$ s time-constant. Do not use more than 10 $\mu$ s.

Using the 'scope measure the amplitude response and the phase response. The latter is vital, and should be the phase delay (not group delay) in microseconds. It's simply the input-to-output delay as you see it on the 'scope, and will be of the order of 150-250  $\mu$ s, fairly constant. If you see a delay of some 1700  $\mu$ s at 300 Hz you are looking on the wrong edge on channel 2. Look carefully  $\frac{1}{2}$  cycle earlier for the correct zero crossing at around 200  $\mu$ s delay; it could be high or low going. You may like to use x5 expansion for the delay, and measure it relative to the centre of the screen. The absolute delay is not important.

Amplitude should be absolute (i.e. Volts, NOT in dB), as measured directly on the 'scope. Please be as accurate as possible;  $\pm 2\%$  is very easy to determine. "Jumps" caused by careless readings necessarily show up again in your customised TX Eprom - as unwanted "noise".

### Calibrating a Whole Channel

If you wish you can characterise the entire channel including transmitter, modem filters and receiver. This has the advantage of being closest to reality, and you don't need an RF signal generator.

Connect the TXAudio to a transmitter, and obtain RXAudio from the receiver discriminator as normal. Set jumper JMP7 OFF, and inject the audio tone into TP2. Measure the system response as above. That is, measure the amplitude and phase delay response from TP2 via TX and RX to TP4 at 300 Hz intervals from 300 Hz to 9600 Hz.

### What To Do With Your Data

When sending the data make sure you identify the test conditions explicitly. Data in electronic form is much preferred, either by packet radio, e-mail or on a DOS disc in a plain ASCII file like this:

```
REM Data from John Smith   G9XYZ   1995 Dec 25
REM RX FT123 TX IC456 Whole channel, TP2 - TP4
REM Freq, Amp, Delay
DATA 0, 1.00, 210
DATA 300, 1.00, 211
DATA 600, 0.99, 213
DATA 900, 0.98, 214
.. etc ..
DATA 9300, 0.12, 245
DATA 9600, 0.11, 246
```

Note the use of REM and DATA statements, and *comma* separators. You may like to include a *ReadMe* file with additional comments.

Send the data, together with your name, address, instructions and £5 Sterling cheque, eurocheque, bank draft, cash or \$10US to the address below. In return you will receive one 27128 Eprom and data sheet, programmed with FIR coefficients to compensate the response you measured.

If you send two or more responses please state whether you want two or more eproms or whether you require all responses in just one eprom. You must send £5 per eprom. These charges are for the IC and postage, at basic cost.

## SECTION 6 - CONSTRUCTOR'S FOLLOW UP SUPPORT

You are invited to contact G3RUH with any technical enquiries about this project. You'll get a reply by return - provided you supply a stamped addressed envelope (or 4 IRC). He can also build and/or test your modem PCB by prior arrangement, as well as generate custom TX Eproms.

James R Miller, 3 Benny's Way, COTON, Cambridge, CB23 7PS, England.

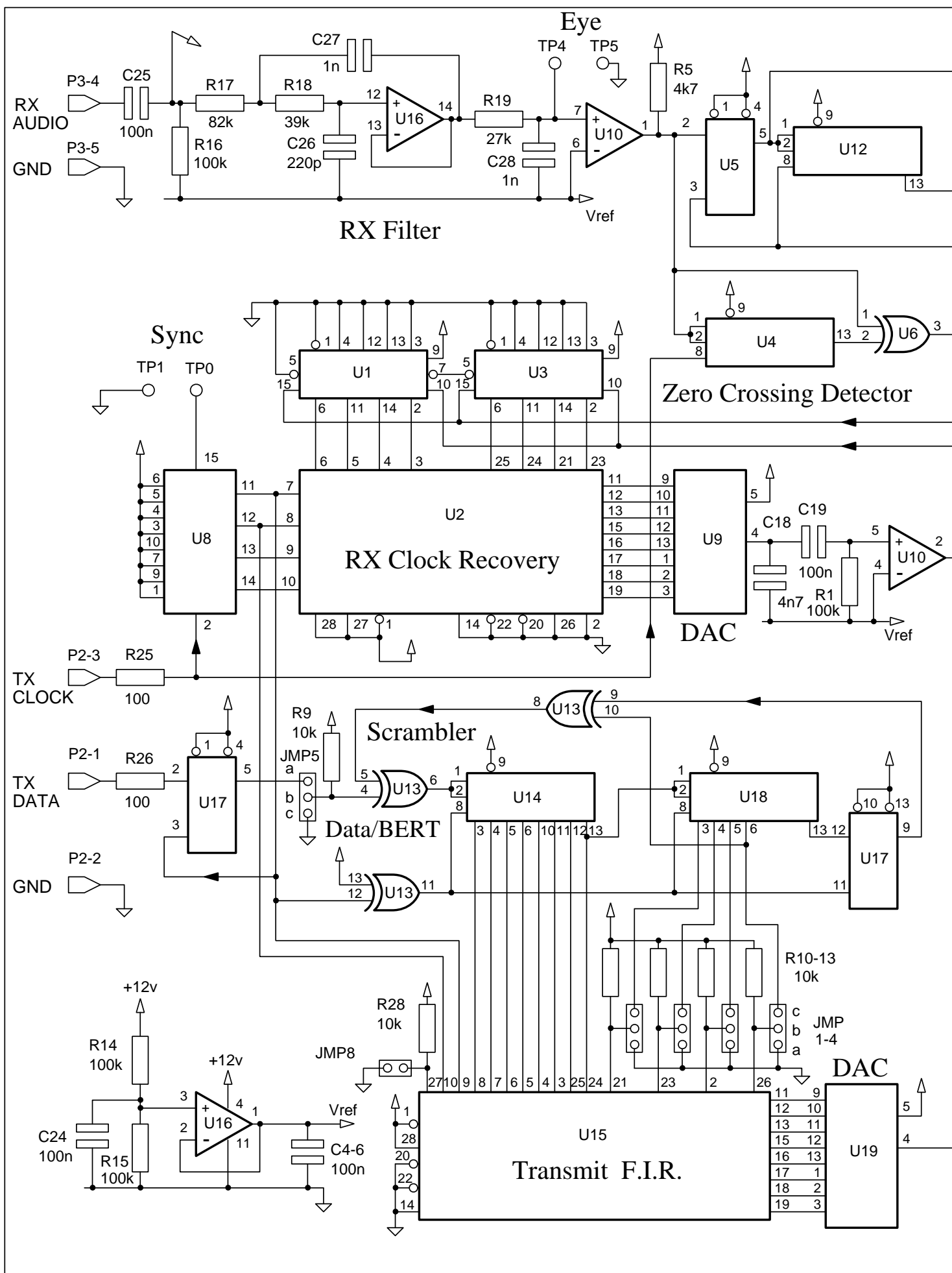



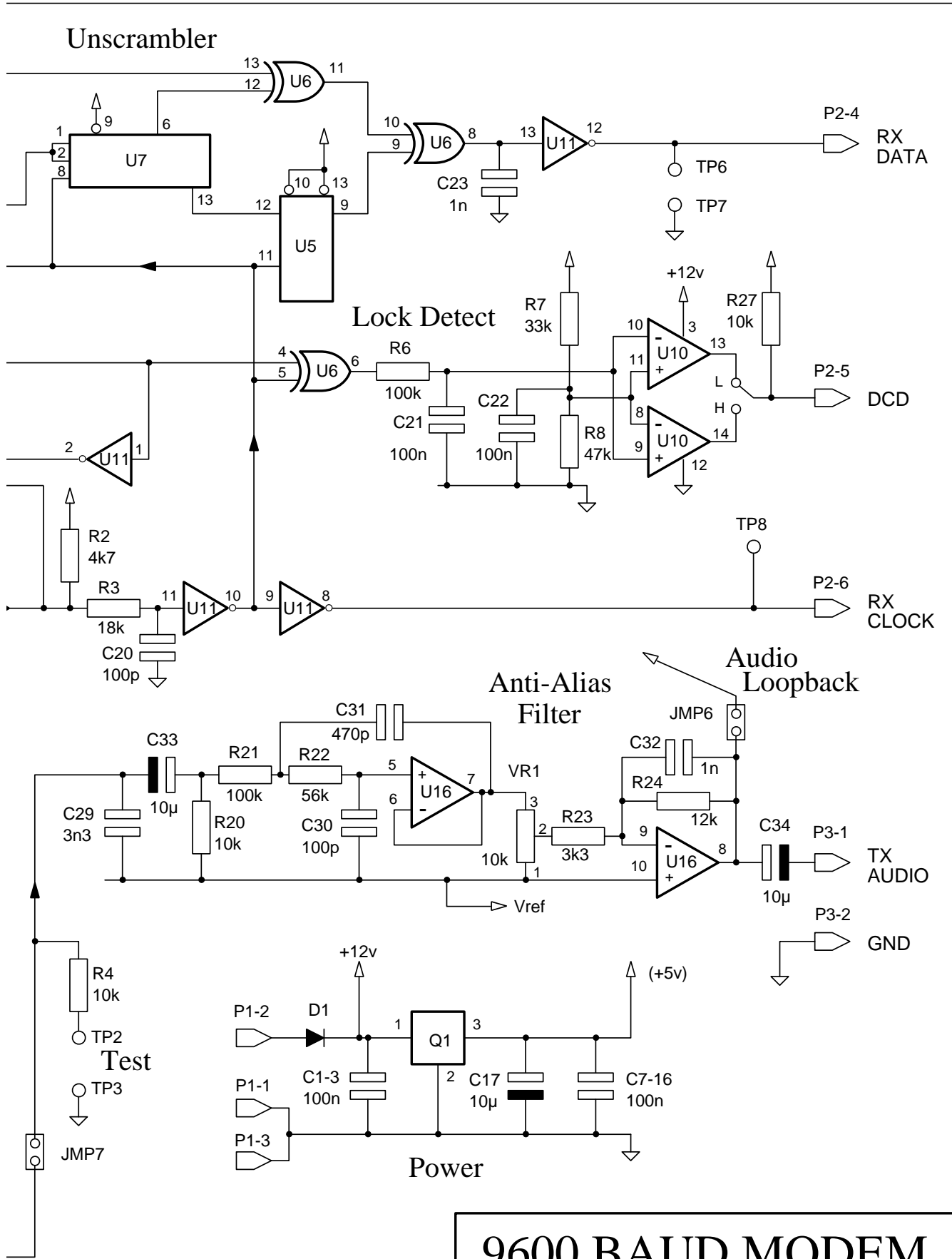

<b>9600 BAUD MODEM</b>	
©1988-94 J R Miller G3RUH	
Issue 3	1988 Aug 20

## SECTION 7 - COMPONENTS LIST

(See Section 12. for 19200 baud changes)

### RESISTORS - (All 2%, 0.4" pitch)

R1,6,14-16,21	100k (6)	R8	47k	R22	56k
R2,5	4k7 (2)	R17	82k	R23	3k3
R3	18k	R18	39k	R24	12k
R4,9-13,20,27-28	10k (9)	R19	27k	R25,26	100 (2)
R7	33k	Note: 4k7 = 4700 Ohms, etc			

VR1 10k Cermet Trimmer e.g. Spectrol 63, 64 series,  
Bourns 3386, 3266, 3296 etc. PCB Drilled for all types.

### CAPACITORS

C1-16,19,21-22,24-25	100n	20% monolithic (21)	0.1" pitch (NOT 0.2")
C17,33-34	10 $\mu$	16v tantalum (3)	0.2" pitch
C18	4n7	20% monolithic ceramic	0.1" pitch
C20	100p	20% monolithic ceramic	0.1" pitch
C23	1n	20% monolithic ceramic	0.1" pitch
C26	220p	2.5% polystyrene	Note: 100n = 0.1 $\mu$ 10n = 0.01 $\mu$ 4n7 = 0.0047 $\mu$ 1n = 0.001 $\mu$ etc
C27-28,32	1n	2.5% polystyrene (3)	
C29	3n3	2.5% polystyrene	
C30	100p	2.5% polystyrene	
C31	470p	2.5% polystyrene	

### INTEGRATED CIRCUITS

U1,3	4029 (2)	Up/down counter
U2	27C64	Eprom - RX (or 27C128 and/or NMOS)
U4,7,12,14,18	74HC164 (5)	8-bit shift register
U5,17	74HC74 (2)	Dual D type
U6,13	74HC86 (2)	Quad EXOR
U8	74HC161	4-bit counter
U9,19	ZN429E-8 (2)	DAC (or ZN426E-8), Ferranti or GEC Plessey
U10	LM339N	Quad comparator
U11	74HC14	Hex Schmitt inverter
U15	27C128	Eprom - TX (or 27C256 and/or NMOS)
U16	TL084CN	Quad op-amp

### MISCELLANEOUS

TP0-8	Test points (9)
JMP1-5	3-pin header, male, SIL, 0.1" pitch
JMP6-8	2-pin header, male, SIL, 0.1" pitch
8 x Shorting jacks - 0.1" for JMP1-8	
P1	3 pin connector, male, SIL, 0.1" pitch )
P2	6 pin connector, male, SIL, 0.1" pitch ) e.g. Molex etc
P3	5 pin connector, male, SIL, 0.1" pitch )

D1 1N4001 diode (or equivalent 1 amp)

Q1 LM340T5, LM7805CT etc 5V TO-220 voltage regulator  
1 x Redpoint TV46 (TO-126 size) Heatsink. 27 °C/W, 22x19 mm  
1 x M3x6 screw and nut

IC sockets: 2 x 28-pin. (Optional 14 x 14-pin, 3 x 16-pin). Turned-pin type recommended.

1 x PCB. Notes: Board is single Eurocard size, 160 x 100mm. Double sided, plated through, max copper ground-plane, solder resist and legend. Drilled for an optional DIN 41612 96 way connector. Four 3.3 mm mounting holes provided on 6.05 x 3.50 inchcentres. Two spare 16 pin IC positions.

A suitable heatsink can also be fabricated from a piece of 1.6mm aluminium, 19mm wide x 40 mm, folded into a "U" shape 19x20 and 10mm high sides, and a 3.3mm hole drilled in the centre.

## SECTION 8 - CONSTRUCTION

The usual caveats apply when populating the board. Don't try to assemble light electronics with a poker! A fine tipped iron and fine gauge resin cored solder are essential. Proceed methodically, checking each soldered joint for integrity immediately you have done it.

Solder the underside only. Apply heat to the component leads, NOT the hole. Good soldering will flow sweetly through the hole and be visible from the both sides. All component leads must be bright and shiny. Junk box parts will probably be filthy. Clean them first - and the PCB if it's been handled. It's far more difficult to remove a component later than to do things right first time. IC sockets are a useful precaution, and essential for the TX Eprom.

Fit components in ascending order of height - diodes, resistors, IC sockets (or ICs), capacitors, trimpot, jumpers, connectors (if you want them), regulator and heatsink. Observe polarity of tantalum capacitors and all semiconductors. Check resistor values before insertion. If using IC sockets do not fit ICs yet; install them only after PSU tests.

Be sure to fit trimpot VR1 correctly, as the PCB is drilled for three possible pin configurations (check the legend and underside tracks).

For the finishing touch, deflux the board on completion. Besides looking good, this will help expose any solder defects. Surprisingly, a very common fault is unsoldered components, often whole ICs!

## SECTION 9 - TESTING AND TEST EQUIPMENT

No adjustments are needed. Assuming there are no faults whatsoever the modem is ready for use. However you should also perform the confirmatory performance tests. DO NOT attach TNC or radios at this stage. You will need a dual trace oscilloscope, and a multimeter.

### 9.1 INITIAL CHECKS

1. If you used sockets, remove all ICs. Apply 12 Volt power to P1. Verify that 12 Volts is maintained at U16 pin 4. Verify that 5 Volts is present at U15 pin 28. DO NOT PROCEED IF THESE TESTS FAIL. If they do, you have a power supply problem which must be fixed first. Check for solder bridges, faulty or misplaced components.

2. Remove power, insert U16, and reapply power. Check for approximately 6 Volts (half the power supply voltage) at U16 pin 1.

3. Remove power. Now insert all ICs. Observe polarity. All notches go to the top of the board. A 2764 or 27128 is assumed to be at U15. JMP8 OFF. Re-apply power and check that 12V and 5V are maintained. Check the 12 Volt power consumption is appropriate (about 40-60 mA with CMOS eproms, up to 170 mA with NMOS). Regulator Q1 will be slightly warm with NMOS.

4. With a multimeter check the voltages on every pin of P2 and P3. They MUST lie between 0 and +5 Volts. If for any reason a higher voltage is measured, FIND OUT WHY and put it right. There will almost certainly be a soldering error, component failure or wrong item fitted, which could damage TNC or radios.

5. You must now connect a 153.6 kHz TTL clock to P2 pin 3, ground pin 2. The proper place to obtain this is from the TNC. Neither transmitter nor receiver will work without this clock, so make all the connections to the TNC now, as described in section 3.2, TNC Connections.

### 9.2 TRANSMITTER

6. Install jumpers thus: JMP1-4 ON a-b (TX selection 0), JMP5 OFF, JMP6 OFF, JMP7 ON, JMP8 OFF. Set VR1 to mid position.

7. Switch power OFF then ON, and install JMP5 ON b-c.

8. Check that a 9600 Hz pulse train is obtained at test point TP0, and then trigger the 'scope from this, time-base 20  $\mu$ s/div.

9. Examine TP2. You should see a rather coarse "eye" pattern at an amplitude of about 2 Volts pk-pk. Examine the signal at JMP6 (left), and you should see a smooth "eye". Vary VR1 and note that the

amplitude changes. Refer to Section 10 for more information about eye diagrams.

10. Try changing jumpers JMP1-4 ON a-b and OFF, and observe the variety of waveforms. (Do NOT install them ON b-c).

11. Whenever you power up in test mode, always remove and replace JMP5 ON b-c. If you don't do this the scrambler may jam at all "0"s, so no TXAudio will be generated.

### 9.3 RECEIVER

12. Install jumpers thus: JMP1-4 ON a-b (TX selection 0), JMP5 OFF, JMP6 ON, JMP7 ON, JMP8 OFF. Set VR1 to mid position.

13. Switch power OFF then ON, and install JMP5 ON b-c. The modem is now in audio loopback and BERT mode. (see Section 11.1 - Reference, Jumpers for explanations of these modes).

14. Examine TP4, the received "eye" point. If the correct selection has been made from the transmit eeprom U15 (JMP1-4 as required, and JMP8 OFF), you should see a perfect eye waveform.

15. Now use the other trace of the 'scope to view the received clock (RXClock) at TP8. This should show a LOW going edge at the same moment as all the eye traces converge to a point. There may be a little jitter, and possibly a slight displacement.

16. Momentarily remove JMP6, put your finger on TP4, and this RXclock will drift due to hum pickup. Replace JMP6 and the clock should pull in again.

17. Examine RXData at TP6. With JMP5 ON b-c the signal should be LOW. With JMP5 OFF it should be HIGH. With JMP6 OFF it will go high or low or completely random. With JMP6 OFF you should see the DCD LED on the TNC extinguish. (see section 11.3.2 to change DCD polarity).

### 9.4 TNC DIGITAL LOOPBACK

18. Install jumpers thus: JMP1-4 ON a-b (TX selection 0), JMP5 ON a-b, JMP6 ON, JMP7 ON, JMP8 OFF. Set VR1 to mid position.

19. Examine RXData at TP6. With a TNC-2 you should see "flags", one bit in eight, i.e. 00010000 or 11101111 repeated. (Not all TNCs do this; some will simply show high or low).

20. Set FULLDUP ON at the TNC, and MYCALL G3RUH (or your callsign)

21. Now type CONNECT G3RUH, and you should get the \*\*\* CONNECTED to G3RUH message. Type test and you should get a repeat of test. Now DISCONNECT. Observe data at TP6 during this test.

22. Experiment a bit; try CONNECT G3RUH VIA G3RUH,G3RUH,G3RUH etc. When you have finished don't forget to remove JMP6, and set FULLDUP OFF.

73. Congratulations! Your modem is now working correctly with the TNC.

## SECTION 10 - EYE DIAGRAMS

The eye diagram is a simple yet powerful way of deciding whether or not the received audio is of satisfactory quality. You can see what a good eye looks like using audio loopback.

Power the modem, with P2 connected to the TNC. Remove Radio connector P3. Install jumpers JMP1-4 ON a-b (TX "loopback" selection 0), JMP5 ON a-b, JMP6 ON, JMP7 ON, JMP8 OFF. Set VR1 to mid position. Trigger the 'scope from TP0, timebase set to 1ms/div. Put a probe on TP4, the "Eye" point. At this slow speed the waveform looks rather like familiar digital "data" but with sloping edges, and a little overshoot.

Now gradually speed up the timebase to 20µs/div. See how the data bits become superimposed, fusing into a characteristic "eye", the diamond shape in the centre of the screen. Notice the traces converge at two distinct points, one high corresponding to a "1" bit, the other low for an "0" bit. At these convergence points the modem samples the audio to detect a "1" or an "0".

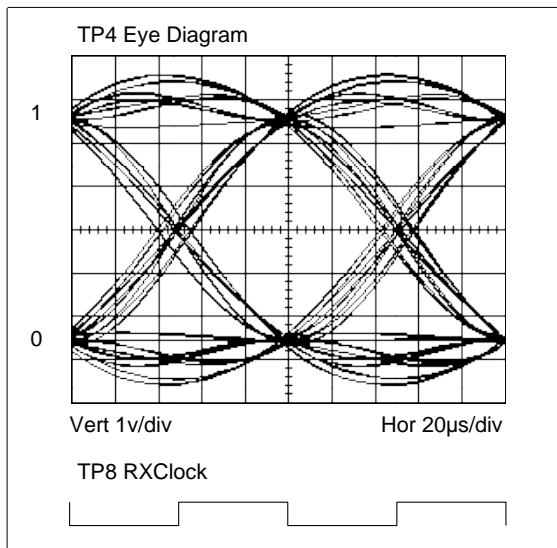

Clearly the goodness of this convergence is an indication of the way the modem will perform. Vertical scatter at the sample point reduces the system's tolerance to noise, because some bits pass closer than others to the mid-screen decision threshold. This scatter is "self-noise", and adds to any real noise present.

Now as an example, change jumpers JMP1-4 to select another transmit waveform. You will see the eye change somewhat, with scatter at the sample point, as well as some asymmetry. However if this audio were passed through its matched transmitter/receiver combination it would convolve back to the ideal shape. It is this compensatory feature of the modem which contributes mainly to its high performance.

When using a real radio link, trigger the 'scope from TP8, the RXClock. It will add lateral jitter due to the clock recovery process, and give a stationary eye.

## SECTION 11 - REFERENCE DATA

### 11.1 JUMPER FUNCTIONS

Eight jumpers are provided on the modem PCB to configure the system, and allow user experimentation. Positions for NORMAL operation are:

Jumper	Function	Normal Position
JMP1-4	TX Waveform Select	As required
JMP5	Data/BERT Mode select	ON a-b
JMP6	Audio loopback	OFF
JMP7	TX DAC Connect	ON
JMP8	TX Waveform II	OFF

#### JMP1-4 TX WAVEFORM SELECT

The transmit waveform generator uses a look-up table of values stored in Eprom U15. Depending on the contents of this Eprom, and the selections of JMP1-4, a variety of transmit waveform characteristics may be achieved to suit differing radio channels.

JMPx	Position	Function (x = 1,2,3 or 4)
OFF		TX Waveform Selection bit x = 1
ON	a-b	TX Waveform Selection bit x = 0
ON	b-c	TX Waveform uses DATA bit x+8

In the standard configuration, the generator operates on a span of 8 data bits at once via shift register U14. A 27128 Eprom can hold up to sixteen different waveform characteristics:

Bit x 4321	TX Waveform Selection	Bit x 4321	TX Waveform Selection
0000	0	1000	8
0001	1	1001	9
0010	2	1010	10
0011	3	1011	11
0100	4	1100	12
0101	5	1101	13
0110	6	1110	14
0111	7	1111	15

Refer to data sheet supplied with eprom for details of characteristics.

Alternatively, it could hold eight characteristics operating on 9 data bits (JMP1 = ON b-c) and so on, up to one characteristic spanning 12 data bits (JMP1,2,3,4 = ON b-c).

Non-standard or customised Eproms are supplied with linking information their data sheet. For example a type 27256 Eprom can hold 32 waveforms in 2 banks of 16, selected by jumper JMP8.

## JMP5 DATA/BERT MODE SELECT

BERT = Bit Error Rate Testing. In BERT mode, the transmitter generates a specific sequence of 131071 pseudo-random bits. At the receiver, after unscrambling, the received data (RXData) should be a constant 0 or a constant 1. However, if a received bit is corrupted, then there will be burst of exactly 3 error pulses on RXData. These are easily counted, and provide a measure of the channel quality.

If there are N counts in T seconds, the channel's bit error rate is  $(N/3)/(T \cdot 9600)$ . For example a count of 30 in 10 seconds would equate to an error rate of approximately 1 in 10000 bits or  $BER = 10^{-4}$ .

JMP5	Position	Function
ON	a-b	Normal DATA
ON	b-c	BERT mode - all 0
OFF		BERT mode - all 1

NOTE: If the modem is powered up with JMP5 set for a BERT mode, the TX scrambler may jam, and no TXAudio will be generated. Remove and replace the jumper as required. The NORMAL position of JMP5 is ON a-b (LEFT).

## JMP6 AUDIO LOOPBACK

Installing JMP6 connects the transmitted analogue audio signal to the modem receiver input. This allows a modem performance check to be carried out without radios. The NORMAL position of JMP6 is OFF.

## JMP7 TX DAC CONNECT

Removing JMP7 disconnects the transmitter waveform generator. This allows a test source to be connected to test points TP2 and TP3. You would do this to perform radio checks or calibrate a channel (see section 5). The NORMAL position of JMP7 is ON.

## JMP8 TX WAVEFORM SELECT II

If U15 is type 2764 or 27128 this jumper must be OFF at all times. If U15 is type 27256, JMP8 should be ON for TX waveform selections 0-15, and OFF for selections 16-31. See JMP1-4.

## 11.2 TEST POINTS

Five test points facilitate monitoring. Each has an associated Ground:

Point	Function	Ground
TP0	9600 Hz Sync	TP1
TP2	Transmit audio inject	TP3
TP4	RX "Eye" Point	TP5
TP6	Received Data	TP7
TP8	RX recovered Clock	TP7

### TP0: 9600 Hz Sync

This is a positive 5 Volt pulse of duration 1/16th bit, at 9600 Hz. It should be used as a "sync" to trigger a scope when examining waveforms.

### TP2: TRANSMIT AUDIO INJECT

With JMP7 removed this point allows a test audio signal to be injected into the transmit system. In this way the radio may be checked, and a radio transmitter/receiver combination can be checked/calibrated. (See section 5).

### TP4: RX "EYE" POINT

This point allows the received audio to be examined just prior to the data detector. The characteristic trace of numerous bits superimposed resembles an "eye". This analogue signal is sampled on the low going edge of RXClock (TP8). The desired trace has symmetry, an open "eye", with all trajectories converging to a spot at the sample point, once per bit. (See diagram, section 10).

### TP6: RX Data (RXData)

This is the 5 Volt TTL signal sent to the TNC. In data mode this will be essentially random. In BERT mode it will be high or low, punctuated by any errors. (See notes about JMP5)

### TP8: RX Recovered Clock (RXClock)

This is a 5 Volt TTL symmetric 9600 Hz clock signal recovered from the received audio. It goes HIGH mid-bit. NOTE: RXClock will take the frequency of the distant transmitter. It will only be identical with TP0 in Audio Loopback Mode (see notes on JMP6).

## 11.3 CONNECTORS

Power Supply		Digital		Radio		Optional DIN 41612	
P1	Signal	P2	Signal	P3	Signal	P4	Signal
1	GND	1	TXData	1	TXAudio	A1-A32	No
2	+12V	2	GND	2	GND	B1-B32	pins
3	GND	3	TXClock	3	-	C1-C32	assigned
		4	RXData	4	RXAudio		
		5	DCD	5	GND		
		6	RXClock				

### 11.3.1 POWER SUPPLY P1

Pin 1 & 3 Ground (-)

Pin 2 +10 to 15 Volts DC at 40 mA (CMOS Eproms) 170 mA (NMOS Eproms).

### 11.3.2 DIGITAL SIGNALS P2

This connector links to the "modem disconnect" or "External Modem" facility of the associated TNC (J4 of a TAPR TNC-2). All signals are standard 5 Volt TTL. A TTL high or "1" is greater than 2.4 Volts, but less than 5.25 Volts. A TTL low, or "0", is less than 0.8 Volts, but greater than -0.4 Volts. DO NOT connect anything other than a TTL device (or appropriate test equipment) to P2!

#### Pin 1 TXData

A signal from the TNC, and is the data to be transmitted. It is read by the modem on a high going edge of TXClock. This signal is provided by a TNC-2 at J4 pin 19.

#### Pin 2 GND

Common connection for the digital signals. This service is provided by a TNC-2 at J4 pin 15.

#### Pin 3 TXClock

A signal from the TNC, and provides timing for the modem. Its speed must be 16 times the data rate (153.6 kHz for 9600 baud). This signal is provided by a TNC-2 at J4 pin 11.

#### Pin 4 RXData

A signal to the TNC, and is the received data as decoded by the modem. This signal is sent to a TNC-2's J4 pin 17. (The TNC-2 trace from J4 17-18 MUST be cut).

#### Pin 5 DCD

A signal to the TNC, "data detect". It is a LOW when the modem recognises that the received audio is a valid data stream. This signal is sent to a TNC-2's J4 pin 1, and will light its DCD LED. Alternatively a DCD HIGH signal is available at U10 pin 14. Carefully cut the short trace on the underside of the PCB that links U10 pin 13 and adjacent VIA (hole), and solder a wire link in the box labelled "DCD" on the top of the board, located between U10 and R6.

#### Pin 6 RXClock

A symmetric 9600 Hz clock signal extracted from the received audio, and goes HIGH in the middle of a RXData bit ( P2 pin 4). This signal is NOT required by a TNC-2, which has an internal clock extract system.

## 11.3.3 RADIO CONNECTIONS P3

### Pin 1 TXAudio + Pin 2 GND

The audio signal to the transmitter, used to modulate the varactor diode to generate true FM. The level is adjustable by VR1 from 0 to about 8 Volts pk-pk. The cable MUST be screened.

### Pin 4 RXaudio + Pin 5 GND

The audio signal direct from the receiver's FM discriminator. A level exceeding 50mV is sufficient, but a probe on TP4 should not show clipping. The cable MUST be screened.

## 11.3.4 DIN 41612 CONNECTOR P4

The PCB is drilled for a 32, 64 or 96 way Euro connector. None of the pins is assigned. Bridge pins as appropriate to P1, P2 and P3 pads and test points (TPx).

## SECTION 12 - USE AT HIGHER SPEEDS

The modem is capable of speeds up to 64,000 baud. This limit is set by the maximum rate that the RX DAC chip can operate. These notes describe how to achieve rates from 4800 to 64,000 baud. The slowest speed is suitable for 12.5 kHz channelised radios. The highest suits radios that have broadcast FM bandwidth filters.

To implement a higher speed you need to:

1. Increase the *TXData* rate
2. Increase the associated 16x *TXClock*
3. Change some analogue filter components proportional to the speed increase.

It is not necessary to change either of the eproms. If you are going for a higher speed, it is likely that the radios involved are "specials" and you will already have wide bandwidth and flattish group delay, so the loopback selection 0 from the standard TXBETA1 eprom will be OK.

The table below suggests the best conditions for different speeds.

Comp	Data Rate - Baud				
	4800	<b>9600</b>	19200	38400	64000
R6	220k	<b>100k</b>	47k	22k	15k
R16	100k	<b>100k</b>	100k	47k	15k
R17	82k	<b>82k</b>	82k	39k	12k
R18	39k	<b>39k</b>	39k	18k	5k6
R19	27k	<b>27k</b>	27k	15k	3k9
R21	100k	<b>100k</b>	100k	47k	15k
R22	56k	<b>56k</b>	56k	27k	8k2
C18	4n7	<b>4n7</b>	4n7	1n	680p
C20	220p	<b>100p</b>	47p	22p	12p
C26	470p	<b>220p</b>	100p	100p	220p )
C27	2n2	<b>1n</b>	470p	470p	1n )
C28	2n2	<b>1n</b>	470p	470p	1n )
C29	6n8	<b>3n3</b>	1n5	470p	470p ) 2% or
C30	220p	<b>100p</b>	47p	47p	100p ) better
C31	1n	<b>470p</b>	220p	220p	470p )
C32	2n2	<b>1n</b>	470p	220p	150p )
Deviation	±1.5	<b>±3</b>	±6	±12	±20 kHz ) In FM
IF Bandwidth	8	<b>15</b>	30	60	100 kHz ) service

These modifications have been tested in both amateur and commercial service. All comments gratefully received and added to the database.

### Notes.

---

This manual was prepared on an Acorn *RISC-PC*, with Computer Concepts *Impression Style* software and a Canon *LBP-4* laser printer.